

# Introducing HP Integrity Virtual Machines

A white paper from HP



Introduction .....	2
What are HP Integrity Virtual Machines? .....	3
Why use HP Integrity Virtual Machines? .....	4
Practical consolidation on enterprise-class servers .....	4
Increased utilization and scalability .....	5
More flexibility and faster deployment .....	7
Higher quality and productivity .....	8
Improved system availability and capacity .....	9
HP Integrity Virtual Machines features .....	10
Compatibility with HP Virtual Server Environment and HP OpenView .....	11
Workload management .....	11
HP Instant Capacity .....	11
HP OpenView Management Software .....	11
Software Licensing .....	12
Availability .....	12
For more information .....	12

## Introduction

Today's data centers frequently need to be flexible in meeting the demands of new customers and new projects. Ideally, these demands are met quickly with minimal overhead while providing a relatively high level of isolation from other customers. For most data centers, the best solution is one that uses current capacity to satisfy these new demands while continuing to provide existing customers with the precise capacity they expect. In doing so, data center owners can keep total cost of ownership to a minimum while maintaining a high level of responsiveness to their customers.

To address this challenge, Hewlett-Packard has created the HP Virtual Server Environment, an integrated server virtualization offering for HP Integrity and HP 9000 servers that provides a flexible computing environment maximizing usage of your server resources. The Virtual Server Environment encompasses a number of fully integrated, complementary components that enhance the functionality and flexibility of your server environment including workload management, availability software, utility pricing and partitioning. HP offers the broadest range of partitioning technologies, known as the Partitioning Continuum, which includes hard partitions, soft partitions, and resource partitions.

This paper introduces HP Integrity Virtual Machines (Integrity VM) – an extension of the existing Partitioning Continuum that blends the benefits of HP-UX Virtual Partitions (vPars) and HP Process Resource Manager (PRM). Virtual partitions allow you to create partitions to the granularity of the hardware (CPU, I/O card) with each partition running its own version of an operating system. This is a good approach when applications can utilize resources at the hardware granularity and the applications should be isolated from one another for reliability or version compatibility of the software stack. With PRM, you can create partitions at a granularity below that of the hardware component with all applications running in one instance of an operating system. This is a good approach when applications can cooperate within one instance of an operating system and utilize fractions of hardware resources.

Integrity Virtual Machines combines both of these paradigms, providing a broader range of resource allocation with application isolation. This addresses the situation where an application does not require the full CPU or I/O card – therefore you would like to share hardware resources with another application – but you want the applications in separate versions of an operating system. Conversely, for applications that require more hardware resources, you can create virtual Symmetric Multiprocessor (SMP) servers that deliver the power of multiple CPUs and I/O cards to the application when it needs them.

Figure 1 Integrity VM extends the HP Partitioning Continuum

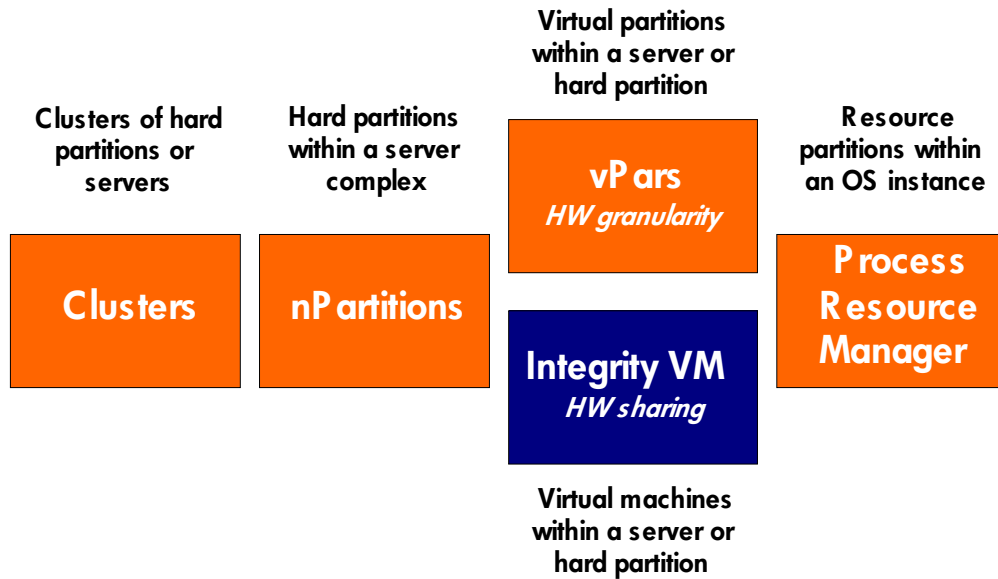

## What are HP Integrity Virtual Machines?

The HP Integrity Virtual Machines product is a robust soft partitioning and virtualization technology that provides operating systems isolation, with sub-CPU allocation granularity and shared I/O. Put simply, Integrity VM enables you to create a virtual machine – a software abstraction that presents all of the interfaces provided by a computer system’s hardware. Integrity Virtual Machines software enables virtual devices by emulating them with real hardware devices. A single HP Integrity server running Integrity VM can support multiple virtual machines, each with its own separate “guest” operating system. As a result, each virtual machine (VM) can host its own applications in a fully isolated environment. The physical resources of the Integrity server are shared amongst any of the virtual machines it hosts. You can define virtual machines as single-CPU or SMP servers with the flexibility to host many virtual CPUs on a single physical processor. The same is true for I/O – a single I/O card can be shared by multiple virtual machines.

HP enables both flexibility and scalability with its Integrity VM technology. You can create virtual servers with multiple, virtual CPUs, and I/O devices, each running separate operating system instances with different OS versions, applications, and users. The result is a virtual machine technology that provides increased hardware utilization and flexibility in server provisioning with isolation, improved system availability, and higher capacity.

## Why use HP Integrity Virtual Machines?

Most data centers have server hardware that is under-utilized. These same data centers almost never have enough servers to satisfy their customers. These seemingly contradictory situations have led administrators to the obvious conclusion for years – “I should be able to make better use of the resources I already have.” There are several virtualization products available today, but HP Integrity Virtual Machines provides a uniquely pragmatic and effective consolidation solution.

The value of Integrity VM is realized in reducing the total cost of ownership for a server environment. This reduction in cost is attributable to practical consolidation, increased overall system utilization and scalability, increased flexibility in configurations, faster server provisioning, higher quality and productivity, and improved system availability with higher capacity.

### Practical consolidation on enterprise-class servers

Before discussing in detail how HP Integrity Virtual Machines achieves these reductions in cost, you should understand the pros and cons of consolidation in the data center. Approaches to server consolidation are varied and can be achieved at many levels:

- Application
- Middleware
- Operating System
- Hardware

Consolidation at any of these levels implies some form of consolidation at lower levels. An example of consolidating at the middleware level is reducing the number of Oracle database instances. It is difficult to combine these instances unless they reside on the same OS instance. That is, the Oracle instances are no longer running on separate OS instances nor do they reside on separate physical servers. Therefore, hardware and OS consolidation has already taken place either explicitly or implicitly.

With consolidation, as with almost any endeavor, 20 percent of the effort gives 80 percent of the benefit. In comparison to other consolidation approaches, consolidating at the hardware level is analogous to 20 percent of the effort. Hardware consolidation with Integrity Virtual Machines enables you to realize most of the consolidation benefit.

Consolidating at other levels requires additional effort for diminishing returns. Application consolidation can be time-consuming and expensive. For example, moving all users to a single mail application, can take months, depending on the organization. It can also have a high level of impact on productivity and morale if not done with much careful planning and support. Similarly, consolidating middleware instances requires a high level of expertise in the middleware, an understanding of how it is being used by the various business applications, and what performance impacts may result from the consolidation. Consolidation of OS instances is frequently blocked by mutually exclusive OS or middleware version requirements (or both). Within a single OS instance, software may be incompatible. In fact, some Independent Software Vendors (ISVs) only provide support on dedicated servers.

Hardware consolidation, that is, multiple “virtual” servers on a single physical server, avoids many of the pitfalls of consolidation at higher levels. HP Integrity Virtual Machines provides a superior hardware consolidation solution, enabling multiple virtual machines with unique OS and application combinations to share the same physical server.

HP offers this consolidation solution on its entire line of Integrity servers presenting a unique combination of a practical consolidation solution with high-performance, enterprise-class hardware.

## Increased utilization and scalability

Very few data centers achieve utilization rates above 40 percent. This is usually the result of two common practices: First, there is typically a one-to-one relationship between applications and servers. Second, many enterprise-class applications are resource-intensive, but the high demand is only for short periods. Virtual machines can be used to improve the ratio of applications to physical resources since it can automatically allocate those resources to the right application at the right time.

Many businesses have applications that are cyclic in nature, such as payroll and end-of-month billing. Frequently, the cycles for the applications do not coincide. Servers are normally configured to handle the peak loads, causing lower average utilization of the server. Integrity VM automatically allocates larger shares of the system resources to applications during the peak usage times. Similarly, during off-peak times, applications can automatically receive a smaller allocation of system resources. In this way, physical resources are utilized by those virtual machines where applications are experiencing a high demand for those resources.

With Integrity VM, a virtual machine is allocated a specified amount of memory, one or more virtual CPUs, and a set of virtual I/O devices; hence, multiple, isolated virtual servers share the underlying physical resources. Integrity VM optimizes this sharing by using HP's proven workload management technology, automatically allocating resources to virtual machines based on demand and entitlement guarantees set for that VM.

Many existing virtualization technologies can provide multiple, single-CPU virtual machines, with one or more virtual machines per physical CPU. Such virtualization enables much more flexibility in the data center in the form of faster provisioning and higher resource utilization. However, this paradigm, depicted in Figure 2, is limited in what class of virtual server it can provide. Because this approach does not scale to more than one CPU per virtual machine, it is not practical for enterprise-class and mission-critical applications that require the scalability inherent in symmetric multi-processor servers (SMPs).

**Figure 2.** Single-CPU virtual machines

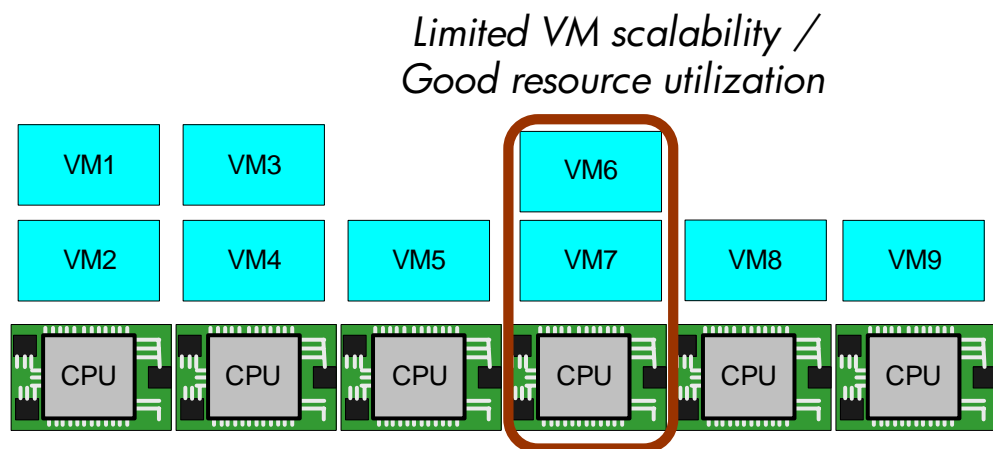

Other technologies can dynamically partition hardware and dedicate resources to those partitions. These technologies provide flexibility in scalability of the individual partitions, allocating one or more CPUs to each partition. Figure 3 shows this approach with hardware dedicated to partitions. However, these technologies are limited in improving utilization because each CPU can be used in only one partition. Furthermore, because at least one CPU must be dedicated to each partition, the number of partitions is ultimately limited to the number of CPUs.

**Figure 3.** Hardware partitioning

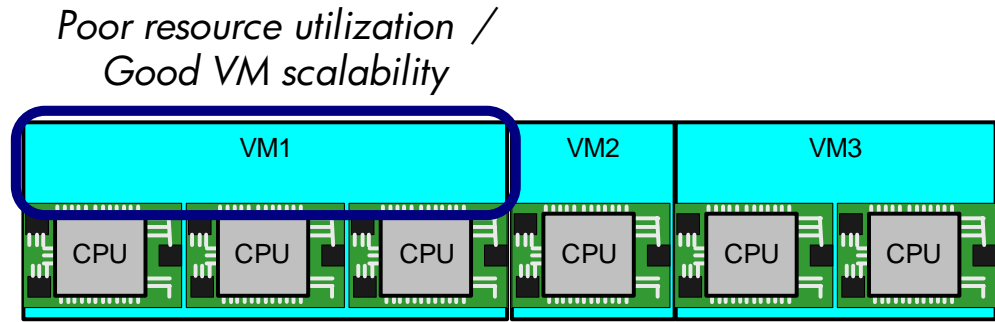

As summarized in Figure 4, Integrity VM combines the best of both approaches. Multiple virtual machines can share the same physical resource, increasing hardware utilization. In addition, a virtual machine can be defined to contain multiple virtual resources, each associated with an underlying physical resource. Resource requirements can then be accommodated by literally allocating multiple physical resources to the virtual machine as needed.

Moreover, physical resource allocation is performed automatically and dynamically. Integrity VM reallocates resources on demand, providing hardware resources to business applications when and where they are needed.

**Figure 4.** Integrity VM offers a consolidation solution providing scalable virtual machines and higher resource utilization

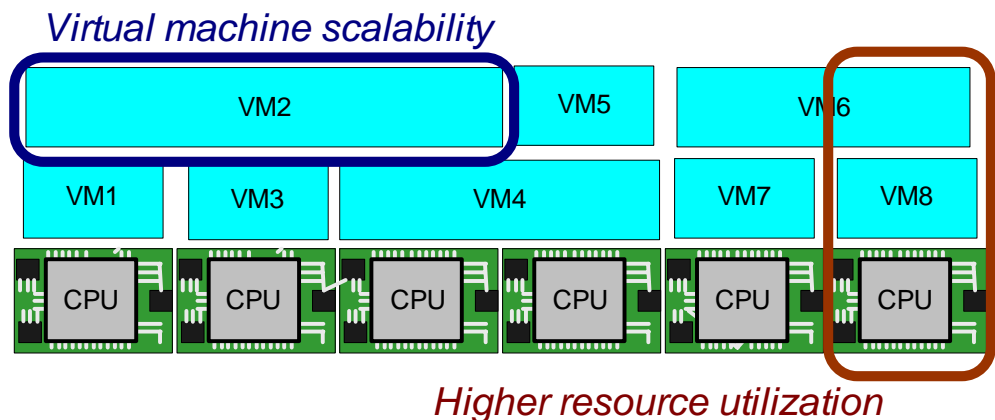

## More flexibility and faster deployment

Integrity VM manifests configuration flexibility in multiple dimensions as illustrated above. Virtual CPU configuration is extremely flexible, offering multiple virtual single-CPU servers and SMPs on the same physical server. Integrity VM also provides flexibility in configuring I/O devices, highlighted in Figure 5. To facilitate better hardware utilization, virtual machines can be configured to share a physical network interface card using a virtual network switch. For situations where the virtual machine requires dedicated access, Integrity Virtual Machines software provides the capability to dedicate one or more devices to a virtual machine.

**Figure 5.** Integrity VM provides superior flexibility in configuration of I/O devices

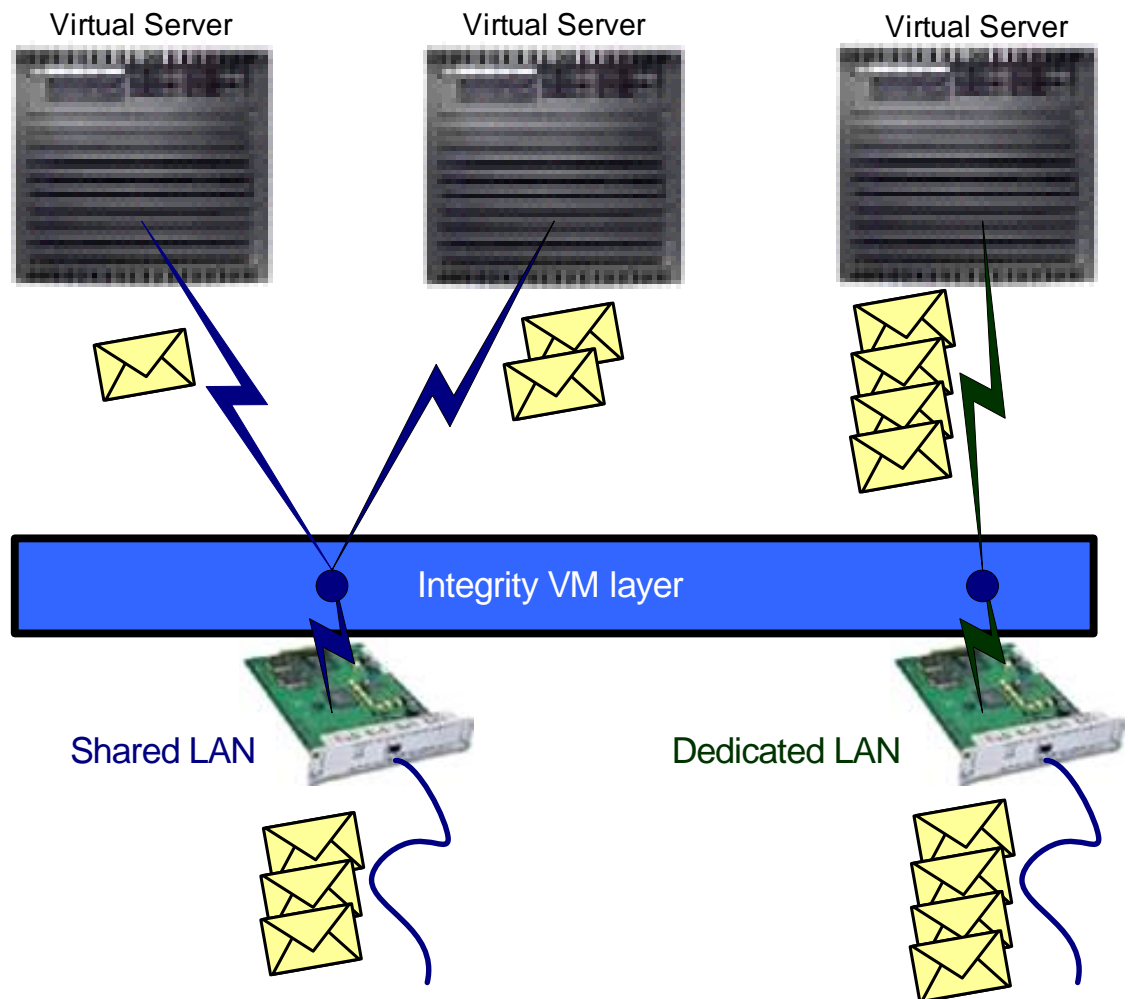

This flexibility is complemented by Integrity VM's ability to deploy a new virtual machine or server in minutes. New virtual servers do not require dedicated hardware cards or CPUs. Virtual I/O, including disk, networking, and DVD, is supported in several ways. For example, a virtual disk can be mapped to a physical disk, logical volume, SAN, or file on the host server.

Users with privileged access can create, deploy, monitor, and perform overall virtual machine management from the host server. You manage virtual machines with either a full set of command-line interfaces or the web-based user interface.

## Higher quality and productivity

Sometimes, operating system adoption rates are slowed because all parts of the solutions that run on the server must be available and qualified before that server can be upgraded. Integrity VM provides a way to do rolling OS and software upgrades on a given server. With Integrity VM, the server can be partitioned into multiple operating system revisions. Those applications available on the new OS release can take advantage of the new features. Those applications not yet available on the new OS can be executed on the same physical system, running an older version of the OS on a separate, isolated, virtual machine.

You can use Integrity VM to set up isolated virtual machines as test environments, perhaps for new revisions of current applications or for deployment of new applications. Integrity VM allows testing in the exact deployment environment while automatically allocating resources only when required. This improves the quality of the test without incurring the cost of repeatedly replicating multiple physical deployment environments.

In addition, Integrity VM enables SMP software development and testing for multiple configurations of virtual SMP servers – all on one host server. On the other hand, prototyping and capacity testing of distributed applications is accommodated by using dozens of virtual machines on a single physical server. Expensive and time-consuming hardware reconfiguration is eliminated. With a few hardware resources, Integrity VM can make dozens of configurations available instantly.

Server replication is made easy through Integrity VM's support of virtual disks by various I/O devices and files. You can enable a new virtual machine in minutes. For example, a virtual machine can be replicated by first copying the host files used by the original virtual machine to new files on the host. Using these files, you clone a new virtual machine configuration with a single command.

**Figure 6.** Multiple hardware, application, and operating system combinations hosted by Integrity VM

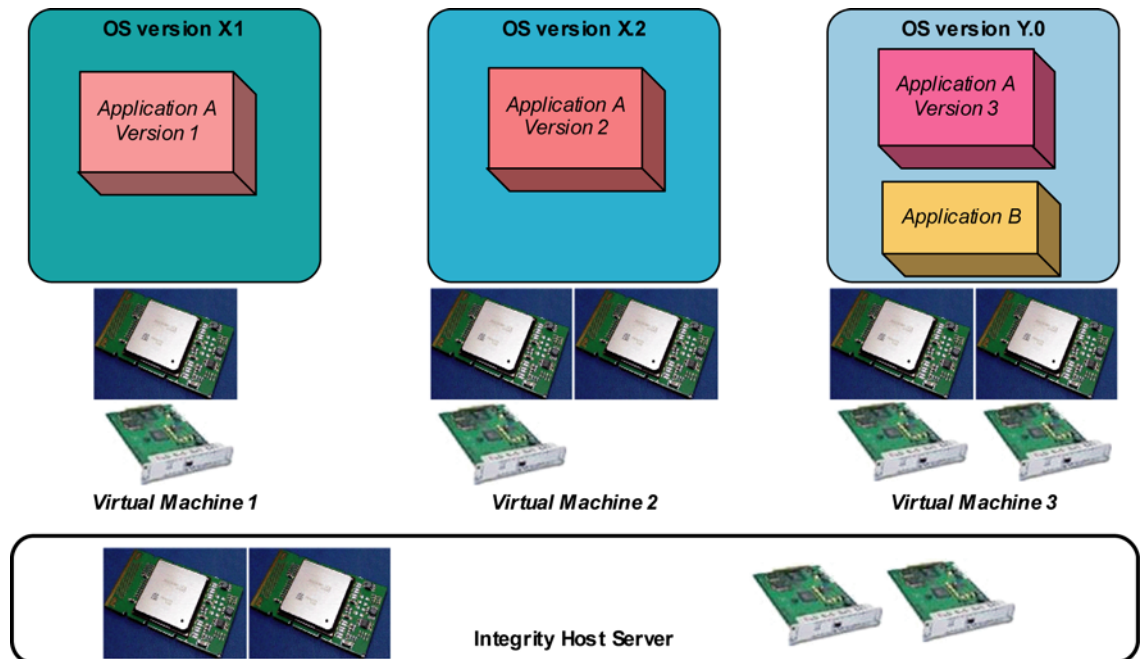

## Improved system availability and capacity

In traditional server environments, all CPUs within a server run the same OS instance and one or more applications. Application and OS failures may affect the entire server. For improved single system availability, Integrity VM allows you to run one application per virtual machine. When an application software failure does occur in one of the virtual machines, that application may be lost, but the applications on other virtual machines continue to run. In fact, even if the OS panics in one of the virtual machines, applications running on the other virtual machines are not affected. In this way, running fine-grained virtual machines limits the impact of application or OS failures on overall application availability.

With Integrity VM, virtual machines are completely separate operating system instances (guest operating systems) isolated by software. Virtual servers cannot read from or write to memory on other virtual servers or the host server. Privileged user access to a VM is limited to that VM – one virtual server cannot be reconfigured by a user on another virtual server.

Some virtualization products use “soft” allocation approaches such as thread prioritization, which do not guarantee a virtual machine its entitled share of the physical CPU. However, when a virtual machine is defined with Integrity Virtual Machines, its CPUs can be allocated a specific share of physical CPU resources. In doing so, the virtual machine is guaranteed to get that portion of the physical resources when needed.

One of the inherent problems in a single system is the difficulty in expanding CPU resources when the demands of the application, or multiple applications, exceed the server’s configuration. Usually the system would need to be shut down and additional CPUs added. With Integrity VM, you can define a virtual SMP server with several (virtual) CPUs. Integrity VM can then allocate at a granularity ranging from a small fraction of CPU resources (an aggregate of much less than one physical CPU) up to a physical CPU for each virtual CPU. This provides the capability to define a larger capacity server while still enjoying the fine-grained sharing of hardware resources.

## HP Integrity Virtual Machines features

In summary, the HP Integrity Virtual Machines product offers the following features:

- Support of low to high-end HP Integrity servers: HP Integrity rx1600, rx2600, rx4640, rx7620, rx8620, Integrity Superdome and other future HP Integrity servers
- Support for numerous virtual machines, both uni-processor and SMPs, on a single Integrity server
- Different virtual machines can run guest operating systems with different versions or patch levels
- Designed for virtual machines running guests with different operating systems (supporting HP-UX 11i v2 at first release)
- Fine-grained allocation of physical CPU resources to virtual CPUs
- Physical CPU sharing – supports multiple virtual CPUs per physical CPU
- Dynamic, automatic reallocation of physical CPU resources to virtual CPUs based on utilization
- Guest OS fault and security isolation
- Virtual machine management isolation – dynamic configuration, boot, reboot, and shutdown without interfering with existing virtual machine operations
- Centralized creation, deletion, replication, and overall management of virtual machines
- Complete software command-line interface
- Shared I/O
- Multiple options for virtual disk support on host:
  - RAID array LUN
  - Physical disk / partition
  - Logical volume
  - File
- Virtual DVD backed by host DVD or (ISO) file
- Virtual console available on all virtual machines with virtualized Intelligent Platform Management Interface (IPMI)
- Full-featured web-based user interface
- Fully supported and serviced by HP

# Compatibility with HP Virtual Server Environment and HP OpenView

HP Integrity Virtual Machines is an important component of the HP Virtual Server Environment. Integrity Virtual Machines is well-integrated with the key elements of the Virtual Server Environment, as well as with many of HP's extensive line of OpenView enterprise management products, a few of which are highlighted here.

## Workload management

Other resource management products can be used within virtual machines created with Integrity VM, including Processor Sets (PSETS), HP Process Resource Manager, HP-UX Workload Manager, and global Workload Manager. Application configurations that involve or rely upon any of these workload management solutions can be moved to a virtual machine configured with these same technologies.

## HP Instant Capacity

Instant Capacity is an option available on many of the HP Integrity servers. This allows you to purchase a fully populated CPU configuration for your server, but only activate a subset of CPUs initially. Additional CPUs can be instantly activated to increase capacity or replace failed physical CPUs on the host. If the Integrity Virtual Machines host has instant capacity processors, they can be turned on without changes to the virtual machines, which immediately take advantage of the additional processing power.

## HP OpenView Management Software

HP OpenView tools such as GlancePlus can monitor or manage individual virtual machines or the Integrity Virtual Machines host. Using GlancePlus on the Integrity Virtual Machines host reflects the physical resource utilization for all virtual machines running on that host. When run in a virtual machine, GlancePlus monitors resource utilization of the virtual CPUs and I/O for the operating system running in that VM.

# Software Licensing

HP Integrity Virtual Machines software will be licensed using Per Core Licensing for each of the active physical cores in the hard partition (nPartition) or server on which it runs.

HP offers Virtualization Licensing for the software run within the Integrity VM virtual machines including the HP-UX 11i Operating Environments and HP-UX 11i Application software offered on a Per Core Licensing basis. Virtualization Licensing allows the following 2 choices for licensing the software:

1. Software may be licensed for all of the active physical CPU cores in the nPartition or non-partitioned server. *(This allows you to run as many instances of the software in the virtual machines as you desire without requiring additional licenses. It is beneficial if you intend to run the same software across all or most virtual machines, or if you intend to change the configuration often and don't want to worry about compliance.)*
2. Software may be licensed for the maximum virtual CPUs that the software will be run on within a virtual machine. *(For example, if you are running HP OnlineJFS in an HP Integrity VM virtual machine with 1 virtual CPU on a server with 4 cores, you could pay for just one Per Core License. This method will be most beneficial when you intend to run the software on only a small portion of the nPartition or system. When applicable, this new licensing option can significantly reduce licensing costs for customers versus previous licensing options.)*

(Note: The above Virtualization Licensing choices are only available for products that are offered on a Per Core Licensing basis. For software products licensed on a per-user or per-server basis, Virtualization Licensing is not applicable.)

## Availability

The HP Integrity Virtual Machines product is planned to be initially available in 4Q CY 2005 on HP's current and future Integrity Servers that support HP-UX 11i v2. In this initial release, Integrity VM will provide guest OS support for HP-UX 11i v2.

## For more information

For additional information, please visit the following sites:

- HP Partitioning Continuum  
[www.hp.com/go/partitions](http://www.hp.com/go/partitions)
- HP Integrity Servers  
[www.hp.com/go/integrity](http://www.hp.com/go/integrity)
- HP Virtual Server Environment  
[www.hp.com/go/vse](http://www.hp.com/go/vse)

© 2005 Hewlett-Packard Development Company, L.P. The information contained herein is subject to change without notice. The only warranties for HP products and services are set forth in the express warranty statements accompanying such products and services. Nothing herein should be construed as constituting an additional warranty. HP shall not be liable for technical or editorial errors or omissions contained herein.

Intel and Itanium are trademarks or registered trademarks of Intel Corporation or its subsidiaries in the U.S. and other countries. Oracle is a registered U.S. trademark of Oracle Corporation. UNIX is a registered trademark of The Open Group.

08 Sept. 2005

