



# HP Simply Consolidation solution guide

Your guide to shared storage for business efficiency

Summer 2008

Simply StorageWorks

For many businesses, the accumulation of data is increasing by more than 100 per cent a year – and new regulatory requirements are only adding to the problem. The challenge is to manage data storage efficiently while controlling costs. HP Simply Consolidation solutions can help you implement simple, affordable and reliable shared data storage for your application servers.

## How can this guide help?

This guide is designed to help you understand the benefits of consolidating your storage by sharing storage from multiple application servers. In addition, it discusses what a storage area network (SAN) does and suggests practical ways to choose the solution that is right for your business. The focus of this guide is on entry-level network storage solutions for small and mid-sized businesses (SMBs). In particular, it features the HP StorageWorks Modular Smart Array (MSA) and the HP StorageWorks All-in-One (AiO) Storage System.

### **Part 1: The importance of consolidating your storage (pages 3–10)**

- Challenges of rapid on-line data growth
- The solution: network storage
- Benefits of storage consolidation
- What is a storage area network?
- The components of a storage area network
- Planning for storage consolidation and SAN deployment

### **Part 2: Assessing your options (pages 11–15)**

- Disk drive technologies
- SAN infrastructure and networking
- HP's approach and unique benefits
- An overview of entry-level SAN arrays

### **Part 3: Choosing the right solution (pages 16–25)**

- Storage consolidation deployment examples
- Choosing the right solution

### **Part 4: Complete your knowledge (pages 26–31)**

- How HP Services can complement your solutions
- Your questions answered
- Jargon buster – simple definitions of key technology terms used in this guide

## Can we help you further?

This guide is part of the HP Simply StorageWorks framework, which provides comprehensive guidance and information about the complete HP storage solutions for small and mid-sized businesses. If you are looking for ways to optimise your file-serving infrastructure, consult the **HP Simply File Services solution guide**. For ways to protect your critical information, refer to the **HP Simply Business Protection solution guide**.

# Part 1: The importance of consolidating your storage



## Challenges of rapid on-line data growth

In the past, there seemed to be only one way for small and mid-sized businesses to handle the exponential growth of data: add more servers to store it. Yet as data accumulation increases – spurred by mounting stacks of e-mail and new legal requirements for business documentation – simply adding servers is not enough to solve most storage problems. Worse, adding extra drives or servers with **direct-attached storage** (DAS) can mean adding extra headaches. Such a solution does not scale up well. It creates an environment that is difficult to manage, often with devices scattered throughout several locations. It adds to the risk of losing your most important data. It is not responsive to business change, sometimes becoming a serious impediment to profitability and growth. In short, simply adding servers is an ineffective way to handle the problems of data storage, resulting in a higher total cost of ownership (TCO).

## The solution: network storage

As a solution to rapid data growth and server proliferation, network storage provides many advantages over the limitations of DAS. A dedicated, optimised network storage solution can vastly simplify management, permit better resource utilisation and protect critical data. Further, network storage is accessible to any computer that can have access to the network, making it easier to scale centrally and protect.

### **Network-attached storage (NAS) vs. storage area network (SAN)**

The network storage solution you should consider will depend on whether you are experiencing growth of unstructured **file data** (office documents, graphics, video, etc.) or structured application data (e-mail or database information), often referred to as **block data**.

**Network-attached storage (NAS)** refers to dedicated, turnkey file server solutions that are quick to install and easy to manage. In contrast, a **storage area network (SAN)** is a way for an application to use capacity on a centralised storage array by employing low-level block access commands. In other words, NAS can be described as file-based data sharing and SAN as block-based data sharing.

**Unified storage**, or all-in-one storage, is another network storage term that describes technologies that allow storage devices to perform both NAS and SAN functions with the same system.

Understanding these terms – files, blocks, NAS, SAN and unified storage – can be invaluable in assessing which storage solution is best for your business.

This HP Simply Consolidation solution guide focuses on HP's SAN solutions. If you think a NAS or optimised file server better meets your needs, refer to the HP Simply File Services solution guide.

## Benefits of storage consolidation

Consolidating your storage can reduce cost and complexity while improving your ability to manage data storage. A properly designed SAN can reduce your TCO and improve your return on investment (ROI).

### Lower costs

- **Better asset utilisation**
- **Higher IT staff productivity** with reduced repetitive management tasks
- **A diminishing 'price per server'**, achieved with consolidated storage

### Mitigate risk

- **Better growth management** through easier scalability
- **Higher data availability and security** with software and hardware tools
- **Faster data back-up and restore** with higher-speed data paths

### Accelerate business growth

- **Faster capacity deployment** by adding capacity without disrupting user access
- **Better data protection** through comprehensive security and replication
- **More flexibility** with choices to meet both immediate and future goals

# Storage consolidation enabler: the storage area network (SAN)

## What is a storage area network?

The simplest way of understanding a storage area network (SAN) is to compare it to an already popular type of IT infrastructure solution: the local area network (LAN), which enables multiple PCs to share key IT resources such as applications, servers, shared files and printers.

In much the same way, a SAN enables you to share storage among many servers. However, storage and servers require a much faster way to communicate than printers. Therefore, there are various choices that can help you to create the best data path between storage and servers.

## The components of a storage area network (SAN)

In the simplest form, a SAN requires:

- Storage that is capable of sharing itself (typically a disk array)
- A network or data path that lets servers and storage 'talk' to each other
- Software that configures the shared environment

Optional components can enhance how you protect the data in a SAN.

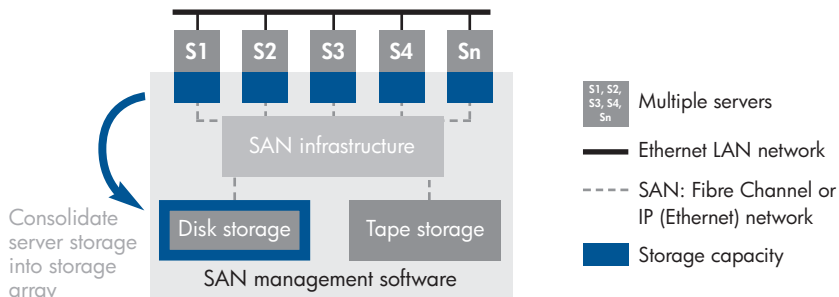

# SAN component no. 1: the disk array

SAN disk arrays are centralised storage pools for servers. Compared with internal disk drives or external enclosures that can be attached directly behind a server, SAN disk arrays enable data consolidation, increased availability, more efficient capacity utilisation and simplified management.

In a consolidated environment, a disk array is shared among several servers. As a result, it is important to design an environment that delivers the level of redundancy and availability that your business requires to avoid application disruption.

## Key benefits and considerations

- **Redundant components:** Hot-swappable fans, power supplies, hard drives, redundant arrays of independent disks (RAID) and multiple data paths help ensure that servers can gain access to their data.
- **Scalability:** With a modular design, the disk storage allows you to increase capacity by adding drives, drive shelves, or controllers.
- **Performance:** Disk arrays with high-speed disk drives and a larger quantity of disks are critical.
- **Data security:** Implement RAID functionality to protect against drive failure.

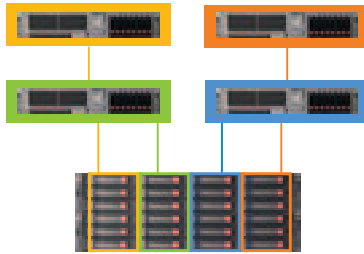

Benefit of a SAN: provides increased availability and capacity utilisation – plus simplified management – by consolidating data in a disk array.

# SAN component no. 2: the network, or data path

The storage network infrastructure, or 'fabric', allows multiple servers to 'talk' to the storage. There are various methods to make this connection – Fibre Channel, iSCSI and Serial Attached SCSI (SAS) interconnections can be used to transmit disk access commands from servers to storage. These options vary by cost, speed and scalability.

- **Fibre Channel** is one of the most widely deployed SAN connection types and uses dedicated Fibre Channel server adaptors, switches and array controllers in the storage system. This dedicated network typically runs at speeds of 4 Gb/s and even 8 Gb/s, and can be designed to be highly fault tolerant and support a greater amount of server traffic.
- **iSCSI** is a SAN connectivity option that runs on standard Ethernet hardware and which reduces the cost and complexity of SAN implementation; these are often referred to as IP SANs. This storage infrastructure is a good option for customers that have a smaller number of servers and do not need multi-gigabit speeds or are evaluating SANs for the first time.
- **Serial Attached SCSI (SAS)** is a common approach for connecting direct-attached storage enclosures to individual servers, but it can also be used to connect multiple servers into a shared array. SAS disk systems are connected to a fixed number of hosts, as there is typically no networking switch involved (e.g., four servers in an application cluster directly attached to a storage array).

When considering a storage infrastructure, an analogy of ordinary roads can be helpful: Fibre Channel is similar to an eight-lane motorway (high speed with room for a high volume of traffic). The IP SAN is like a four-lane road (capable of high speed but with fewer cars). Just as it is more costly to construct an eight-lane motorway than a four-lane road, choosing the right SAN infrastructure is a matter of balancing your needs for performance, scalability and cost.

## Key benefits and considerations

- **Distance:** Speed over relatively long distances. Servers connected to a SAN can reside right next to each other, in different rooms, on different floors of a building, or in different buildings throughout a campus. The servers and storage act as though they are connected locally, providing very fast performance.
- **Fault tolerance:** SAN technology lends itself to multiple cable connections between a server and the storage array, protecting against a cable, controller, or switch failure.
- **High availability:** A SAN is the recommended architecture for server clustering, with two or more servers in the cluster sharing the same storage capacity. Adding data replication makes it possible to build fail-over sites and disaster recovery – protecting data at a second location should disaster occur at the first.

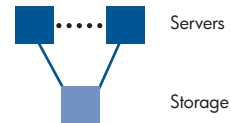
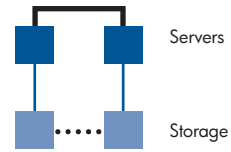

Benefit of a SAN: creates a high-performance, resilient infrastructure that can be modified easily as your needs change.

# SAN component no. 3: the SAN configuration software

Once you have physically connected servers through a SAN infrastructure to a disk array, you need configuration software to provision that storage capacity to specific applications running on your server.

**Physical disk configuration:** The first step of configuration involves grouping physical disks together into a RAID group based on performance, redundancy and capacity requirements. RAID technology protects your disks in the SAN from physical drive failures and can improve application performance by spreading data read/writes across multiple disks.

**Logical disk configuration:** Once RAID groups have been created, you can assign portions of them to one or more servers by creating and assigning a logical unit number (LUN). The software 'carves' portions of the disk capacity and 'gives' the capacity to the corresponding server. For example, you may have 2.5 TB of storage protected in a RAID 5 configuration, with

five servers attached to the SAN. Your finance server may require 500 GB of capacity, your engineering group 1 TB, marketing 500 GB, shipping 250 GB and the legal group 250 GB. The appropriate capacities are selected and assigned to each server. That server 'believes' it owns unique storage. In reality, however, the SAN is a single disk entity that is used by every server.

**Automated configuration:** HP All-in-One (AiO) Storage Systems use HP All-in-One Storage Manager (ASM) software to take a different approach to SAN configuration. ASM reduces complexity by presenting storage in an 'application-centric' framework and integrates well with applications such as Microsoft® Exchange and SQL Server. ASM automates both the physical RAID set-up and LUN assignment for hosts connected to the AiO Storage System via iSCSI.

Benefit of a SAN: enhances efficiency by managing your consolidated storage from one logical location and allows value-added capabilities, building on the infrastructure.

# Optional SAN components: protecting your data

SAN consolidation is typically associated with improving efficiencies in on-line production data, but there are several SAN technologies that can improve your ability to protect your data and ultimately your business.

- **On the disk array:** Array-based snapshots are a technology that allows data stored on the disk system to be captured across points in time, with changes being tracked so that data to be 'rolled back' to a previous point and networks recover from corruption, deletion, or other failures. Cloning is another array feature that allows data to be copied to another set of physical spindles either for additional data protection or for use in testing and application development.
- **Outside of the disk array:** Running back-up over a LAN usually results in the tape drives running at slower LAN speeds. Therefore, one of the key benefits of building a high-speed SAN infrastructure (with Fibre Channel, for example) is its ability to run and push data at the tape drive's maximum speed. Faster back-up and restore provides better protection and recovery of data. Emerging disk-based back-up technologies can also be utilised to tier data on the SAN to disk and then to tape for D2D2T back-up.

Benefit of a SAN: allows server and storage resources to evolve at their own pace without jeopardising the IT investment. Various types of servers and servers with different operating systems can share the storage pool.

# Part 2:

## Assessing your options

Choosing the appropriate technology for your environment



### Disk drive technologies: Serial ATA, Serial SCSI and Fibre Channel disks

Various disk drive technologies can be deployed in a SAN with different complementing benefits.

**Fibre Channel and Serial Attached SCSI (SAS)** disk technology is the right choice for networked application storage, which typically requires ultra-reliable, high-performance storage. If performance is not a primary consideration and your business requires high-capacity, cost-effective storage for file serving, archival data, or reference information, then SATA is a perfect choice.

**Serial ATA (SATA)** disks provide a much lower cost per gigabyte than SCSI, SAS, or Fibre Channel disks. However, SATA disks are not designed for the same level of performance and reliability as SCSI, SAS, or Fibre Channel disk drives.

If your business has requirements for multiple drive technologies, look for disk arrays such as the HP StorageWorks All-in-One Storage System (AiO) and Modular Smart Array (MSA), which support multiple disk technologies that tier data to different drive types depending on the performance and reliability needs of specific applications.

	Serial ATA (SATA)	Serial Attached SCSI (SAS)	Fibre Channel
Capacity	Highest	Moderate	Moderate
Reliability	Moderate	High	High
Performance	Low	High	High
Scalability	Moderate	Moderate	High
Data access type	Moderate	Frequent	Frequent
Price per GB	Low	Moderate	High
Best use	File storage, archival/back-up, secondary applications	Business transactions and primary applications	Business transactions and primary applications

'HP has been a partner who has invested the time to understand our business goals and needs. They provide the best solutions that make the most sense for us. We know that we can trust their word and their solutions.'

Peter Gilbert,  
Director of the  
Information  
Technology  
Services Group,  
London Health  
Sciences Centre

## SAN infrastructure and networking

A storage network needs to be fast and accurate to deliver data. Typically, a dedicated infrastructure is needed to meet the requirement for speed and error-free delivery.

### **Fibre Channel SANs: for larger, more demanding environments**

Because the low-latency Fibre Channel protocol is designed specifically for storage networks, it provides a high level of performance and reliability between servers and storage devices. Over the coming years, Fibre Channel SANs are expected to remain the choice when fully integrated SAN back-up is required and in environments where high performance and availability are critical.

### **IP (iSCSI) SANs: the technology for smaller businesses**

For smaller IT environments, Internet Protocol (IP) SANs are ideal. An existing 1 GB/s Ethernet network will provide sufficient bandwidth to connect several servers to

a SAN storage device. This can be done using either standard network interface cards (NICs) or optional TCP/IP Offload Engine (TOE) cards that offload network tasks from servers with high CPU loads. Performance can be improved by teaming network ports and enabling TCP/IP functions such as Jumbo Frames.

### **Serial Attached SCSI (SAS) arrays: the choice for fixed server deployments**

For environments such as an application cluster, SAS-connected disk arrays are an excellent choice. A direct-connected SAS array supports connection to a shared storage device without requiring any networking or switching infrastructure. A SAS adaptor in the server is connected via a cable to a port in the array. Disks are then zoned for that specific server or cluster. This is an easy and low-cost way to share storage between a small fixed number of hosts.

# HP's approach and unique benefits

## Simple, affordable reliable solutions

To match the IT intensity of your business, the size of your environment and your other business needs, HP gives small and mid-sized companies the choice between an integrated 'turnkey' solution or a customised network solution that groups several types of products.

The **HP StorageWorks All-in-One (AiO) Storage System** family of unified storage devices provides shared iSCSI storage while also supplying optimised NAS file-and-print serving and data protection capabilities – all under a radically simple management umbrella.

These fully integrated systems are designed to be deployed and managed by IT generalists with no storage expertise. The AiO Storage Systems support mixed SATA and SAS hard disk drive (HDD) environments, and are expandable using MSA50, MSA60 and MSA70 storage enclosures.

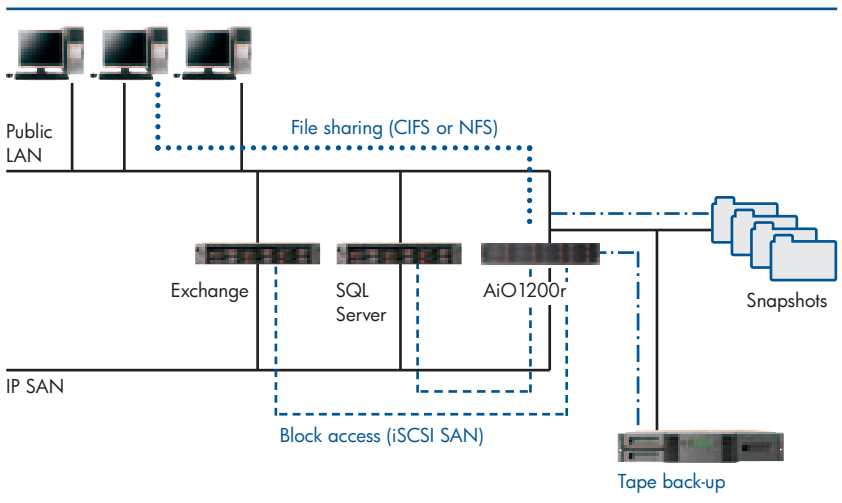

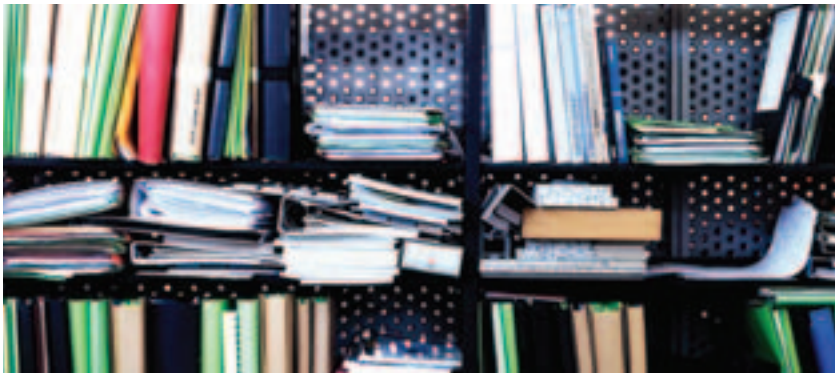

### **Core features of the All-in-One Storage System**

- Includes the Microsoft iSCSI Software Target, which permits consolidated block-based SAN storage for applications running on Windows®, Linux, VMware and more.
- Runs Microsoft Windows Storage Server 2003 R2 operating system, which allows 20 per cent faster file-serving performance and 35 per cent more efficient file storage with integrated deduplication features.
- Provides data protection with an integrated copy of HP Data Protector Express software and supports replication between systems using HP StorageWorks Storage Mirroring software.
- Delivers true ease of use with the All-in-One Storage Manager (ASM) interface, which is designed for IT generalists and automates the set-up of file shares, iSCSI SAN, snapshots, back-up and replication.

For more information on HP All-in-One Storage, visit: [www.hp.com/go/aiostorage](http://www.hp.com/go/aiostorage)

‘With our recent move to a virtual server configuration, we needed a storage device that has a rich feature set and that allows for greater throughput, which our virtual server environment requires. The MSA2000 provides us with these capabilities and at a price we can easily afford.’

Mark Ross, Associate Director/Operations Manager/Storage Administrator, IU Kelley School of Business

The **HP StorageWorks Modular Smart Array (MSA)** family of products enables the construction of a complete storage consolidation solution using several modular components that integrate seamlessly. An MSA solution thus requires a little more planning but provides maximum flexibility, availability and performance.

These robust solutions provide outstanding price/performance features for small clusters, as well as entry-level and mid-range SAN environments. Designed to

maximise transfer rates, reduce management costs and drive a rapid return on investment, each solution supports flexible platforms and advanced data protection features such as snapshots and clones. The MSA family provides reliable, cost-effective storage to address your most demanding needs.

For more information about HP Modular Smart Array (MSA) systems, visit:

[www.hp.com/go/msa2000](http://www.hp.com/go/msa2000)

# Part 3: Choosing the right solution



## Shared storage for an application cluster with MSA2000sa

### Moving from DAS to shared storage as the business grows

Media-Logic is a growing company whose primary revenue stream requires access to a mission-critical database. In order to improve the reliability of their application deployment, they decided to cluster their database servers. Application clustering required shared storage and caused them to look for an alternative that would let them move easily from direct-attached storage.

### The solution

The best way to accomplish this transition was to implement a simple two-node cluster. Two servers participating in a cluster share

an MSA2000sa and are both directly connected to the disk array. In the event of a server or application failure, the secondary server 'takes over' the function of the first server and the business continues to run.

### The benefits

The MSA2000sa has a very simple design and uses familiar cabling and expansion cards to connect servers to the array. With the simplicity of the MSA2000sa, Media-Logic was able to quickly improve their application availability to meet their business objectives.

---

### MSA2000sa scenario

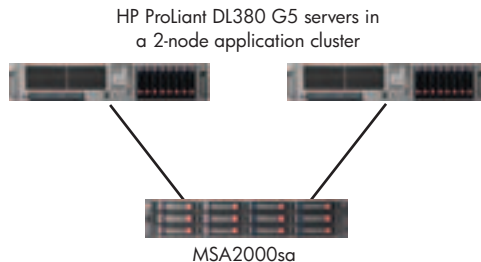

# Cost-effective IP SAN and file serving in a single solution: All-in-One Storage Systems

## Solutions for a small company outgrowing server capacity

Winsure is an insurance company with 100 employees, two offices and only one IT person. Their main office has five servers, but the older file server needed to be replaced and some application servers were running low on space. With a limited budget, they needed a solution that could solve multiple storage problems and be easy to deploy.

## The solution

The HP StorageWorks 1200r All-in-One Storage System (AiO 1200r) replaced their older file server, extended their application server storage capacity with iSCSI and acted as a local back-up server. HP StorageWorks Storage Mirroring, along with a second AiO 1200r at their other office, was used as a replication target to improve disaster recovery by getting data off site.

By having a single pool of storage for application data, file serving and even data protection, they reduced their management costs and increased their ability to respond to growth.

## The benefits

HP All-in-One Storage Systems combined the benefits of an iSCSI SAN and an optimised NAS file server, making it perfect for cost-conscious offices or departments. It can also be used as a disk-based back-up target and consolidation point for data protection, including replication between systems using HP StorageWorks Storage Mirroring.

All-in-One Storage System

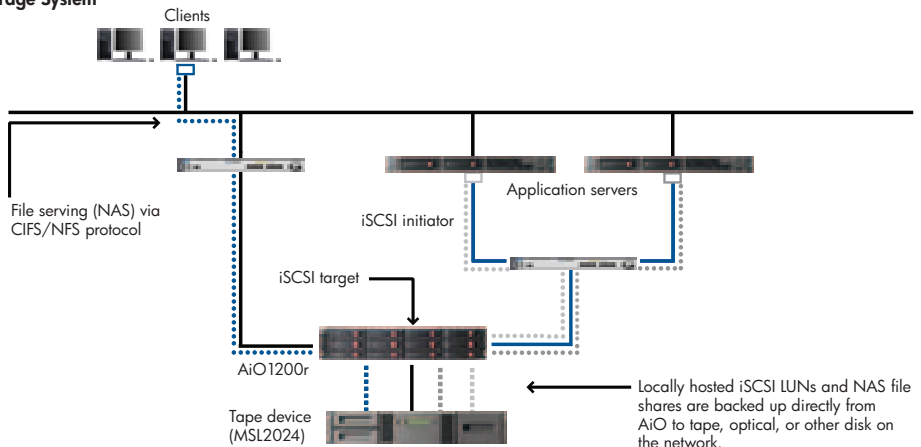

# Scalable and redundant IP solution with MSA2000i

## Unexpected data growth presents a major business challenge

AlphaCorp is a mid-sized financial services company that has recently expanded into a new market and is rapidly outgrowing the storage capacity in their individual servers. They have been adding new servers at a rapid rate and need a better method to control and manage their data. The company needs a flexible and affordable storage solution that gives them redundancy and performance without requiring a significant infrastructure investment.

## The solution

AlphaCorp decided to implement an IP SAN solution with an MSA2000i as a central storage array, enabling the company to expand the disk space flexibly and affordably.

The easy implementation over an IP LAN network and the flexibility of the iSCSI connection enabled AlphaCorp to plan their disk space growth in a controlled and centralised way.

## The benefits

With the scalable MSA2000i solution, AlphaCorp achieved a balance between ease of management and dedicated array performance and availability. The solution is easy to manage and enables the company to grow in a planned and structured way, moving them from a reactive to a strategic approach to storage management.

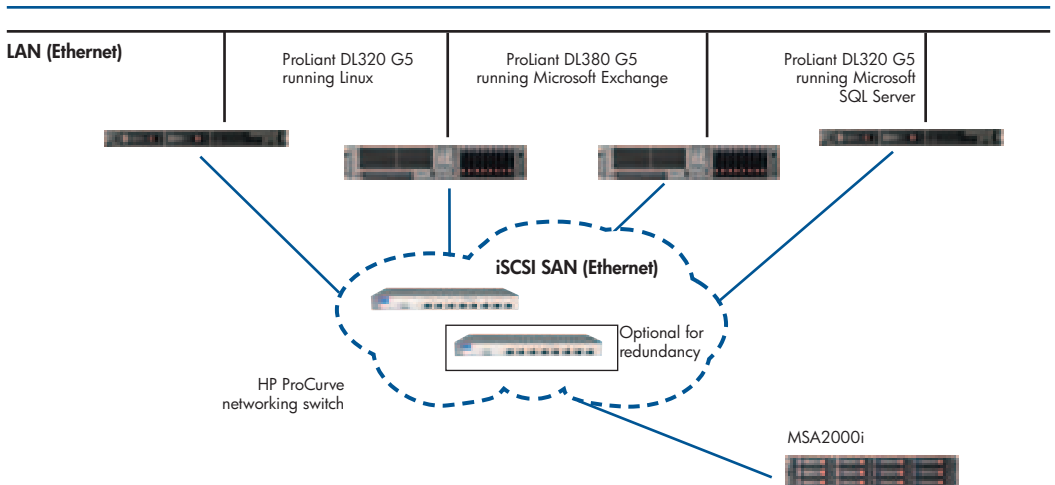

# Fibre Channel SAN with MSA2000fc

## **More business transactions mean a need for higher performance and availability**

ProServe is a midsized professional business services provider with several hundred employees. Their rapid growth has resulted in a distributed server environment with pockets of capacity trapped in direct-attached storage islands. They have decided to take a step back and deploy a dedicated storage array in order to reduce their management costs and improve the efficiency of their IT investments. The company was also looking to deploy server virtualisation technologies and needed a robust storage solution that delivered performance and reliability to support their business.

## **The solution**

The ProServe IT team decided that they needed to implement a Fibre Channel SAN. Fibre Channel gave them the performance and redundancy they needed to add servers easily, implement additional server clusters for their different applications, add redundancy for their critical servers and take advantage of the Fibre Channel SAN for high-speed back-up and restore.

## **The benefits**

When consolidating storage from multiple servers (clustered or non-clustered), a SAN solution based on the MSA2000fc provides outstanding efficiency, flexibility and scalability that provides a greater number of server connections than other SAN architectures.

The association of server blades with the SAN makes the perfect IT building block, permitting maximum efficiencies on both the computing and storage side. Enhancements in the MSA2000fc, such as dual controller capability, make this type of deployment possible with significant improvements in performance.

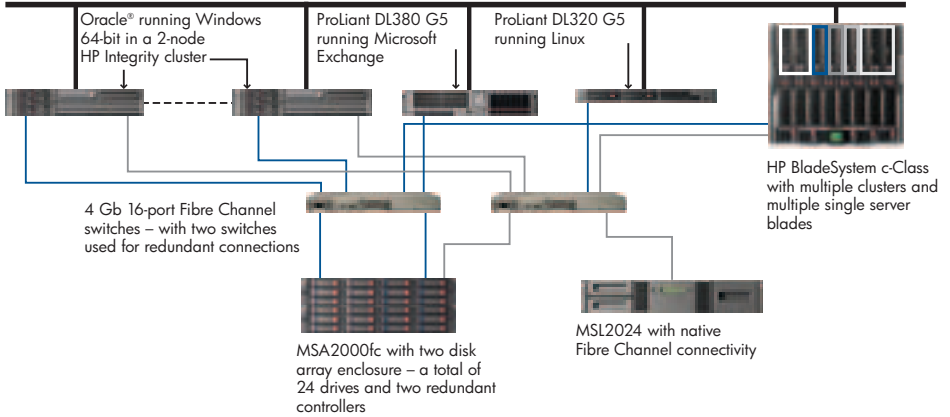

## Cost-effective, disaster-tolerant storage

### When lost data could mean lost business for G-tek

G-tek had already implemented SAN storage in their main office but needed a way to protect data on application servers in their secondary office. If the data on those application servers was lost, they could potentially go out of business. The branch office was protecting data using an HP tape drive in their server, but the IT team determined that the revenue associated with those applications required real-time data protection down to the last transaction.

### The solution

For up-to-the-second protection against many problems, G-tek deployed HP StorageWorks Storage Mirroring, host-based software for Windows and Linux environments that helped replicate data to another server in real time. They chose to locate this replication server in one of their buildings across town so that in the event of a local problem at the production facility, they would be able to gain access to the replication server automatically, ensuring more uptime than ever before.

## The benefits

Storage Mirroring can recover data replicated hours, minutes, or seconds earlier. This replication can complement tape back-up and restore as well as snapshot technologies to add another 'layer' of enhanced data protection.

In the figure that follows, the data is 'copied' from the 'live' environment on the left and sent over the network to the 'replication' environment on the right.

The Storage Mirroring software is designed to take only byte-level changes and send them to the second server or site. This byte-level replication uses the least amount of network bandwidth, giving you an excellent data protection solution – without the need to purchase new communication infrastructures.

## Cost-effective, disaster-tolerant storage

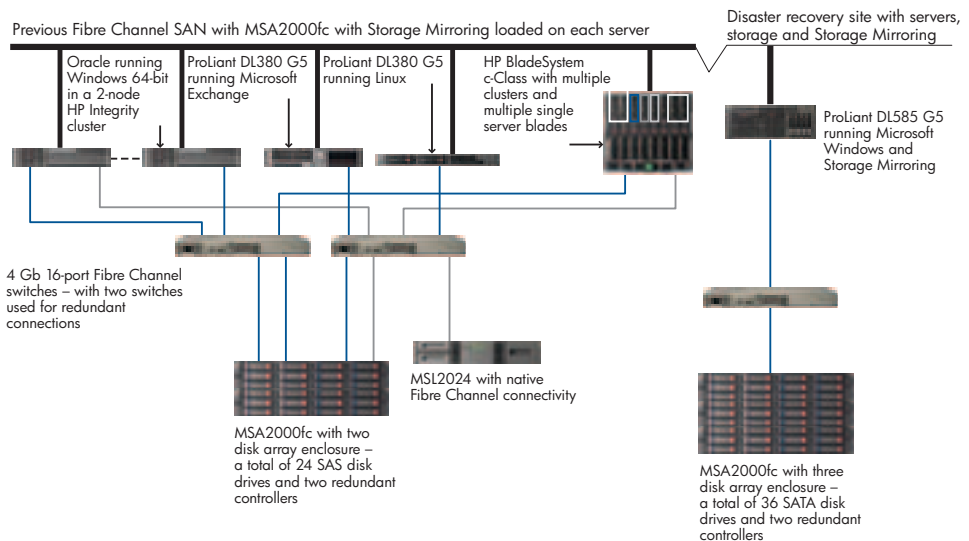

# EVA – combine simple management with performance and availability

If you need increased performance and greater flexibility for demanding mission-critical applications, consider the HP StorageWorks Enterprise Virtual Array (EVA) family.

## Ultimate management efficiency

The HP StorageWorks Enterprise Virtual Array (EVA) family gives you the ultimate in management efficiency, thanks to built-in virtualisation. The EVA aggregates and automates your SAN storage. It presents your storage capacity as a 'virtual' pool, eliminating the physical boundaries between storage and server. This simplifies management and increases your flexibility in building storage pools for applications.

With virtualisation in the EVA, you can save money by not over-investing or over-provisioning disk capacity because the EVA supports dynamic capacity or LUN expansions without taking the array off line. The EVA family provides connectivity through the use of industry-standard or multi-pathing software, such as Multi-path I/O (MPIO), and massive scalability that is limited only by the size of today's disk drives.

The new HP StorageWorks 4400 Enterprise Virtual Array (EVA4400) provides EVA enterprise-class functionality at an affordable price. In addition, you can install the EVA4400 in just a few hours.

By adding software such as HP StorageWorks Dynamic Capacity Management, Business Copy, or Continuous Access, your EVA4400 can assist your workload distribution and data mining.

For more about the HP EVA, contact your HP sales representative or visit:

[www.hp.com/go/eva](http://www.hp.com/go/eva)

# Choosing the right solution

## Which storage area network (SAN) is right for you?

Here is a quick way of choosing the best solution for your specific storage needs.

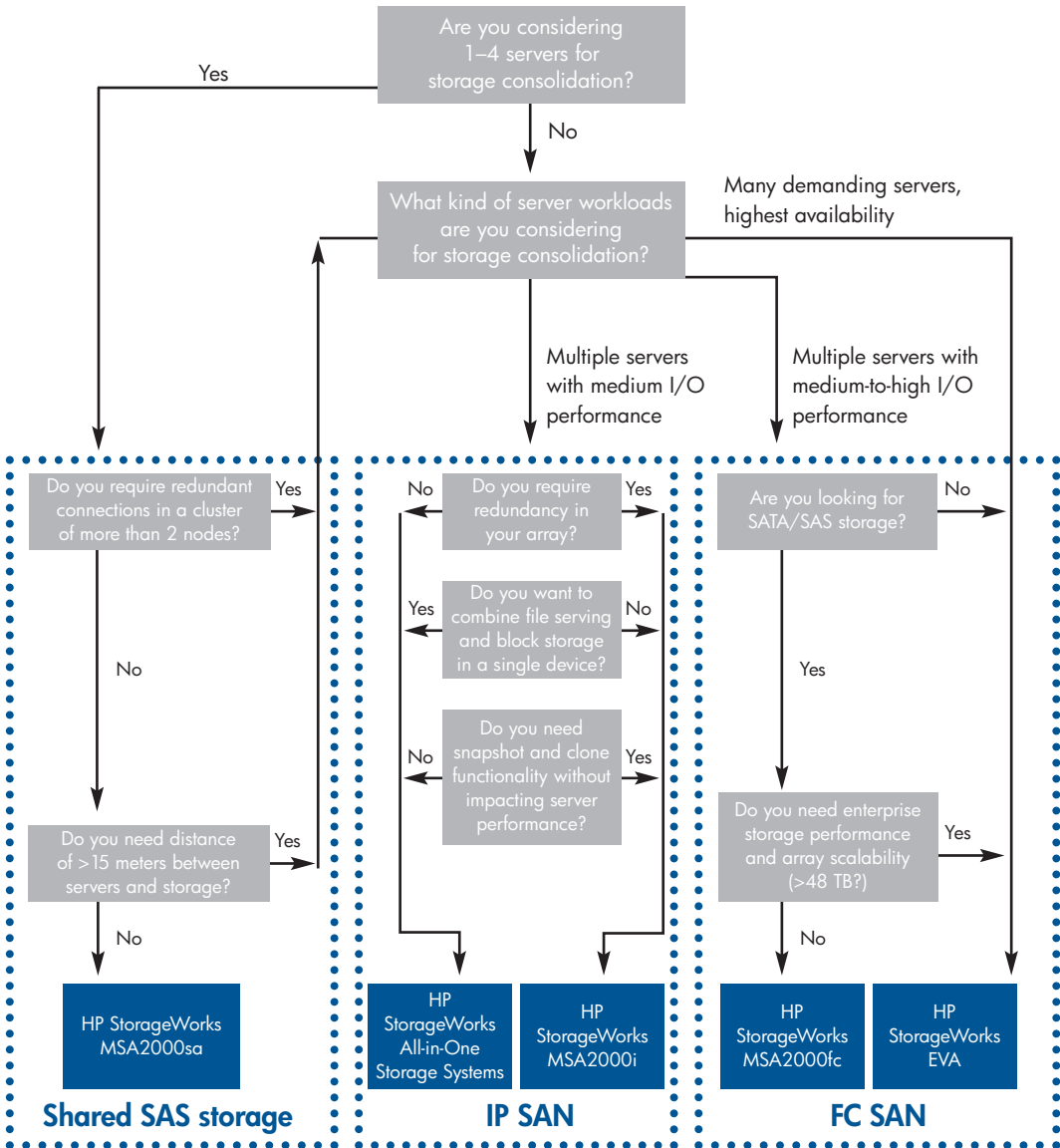

See the QuickSpecs at: [www.hp.com/go/msa](http://www.hp.com/go/msa) for latest product details

# HP's family of products

	HP StorageWorks Modular Smart Arrays	HP StorageWorks All-in-One Storage Systems		
	Entry-level consolidation	Entry-level consolidation and unified storage		
	MSA2000sa	AiO400r/ AiO400t	AiO600	AiO1200r
	Affordable shared storage solution	Entry-level unified IP SAN and NAS solution	Expandable unified IP SAN and NAS solution	Higher-performance SAN and NAS solution
<b>Disk technology</b>	SATA and/or SAS	SATA or SAS	SATA or SAS	SATA or SAS
<b>Scalability</b>	Scale up to 48 TB (SATA) or 14.4 TB (SAS)	Pre-configured up to 2 TB systems with 4 disk slots	Pre-configured up to 3 TB; scalable to over 50 TB with MSA enclosures	Pre-configured up to 12 TB; scalable to over 50 TB with MSA enclosures
<b>Consolidation</b>	Consolidate storage up to 4 servers	Consolidate multiple servers in an IP SAN including shared storage behind a cluster		
<b>Redundancy</b>	Redundant controllers, cooling and power supplies	Hardware RAID controller; MPIO enables multiple paths between servers and storage		
<b>Operating system support</b>	Microsoft Windows, Linux, VMware ESX	Windows, Linux, VMware ESX, QLogic		
<b>Other features</b>	Data replication and server fail-over over LAN or WAN in Windows and Linux environments <sup>1</sup> Snapshots Clones	Includes All-in-One Storage Manager for simple management and migration; provides file serving, replication <sup>1</sup> , snapshots and direct back-up		

<sup>1</sup> Using HP StorageWorks Storage Mirroring

# HP's family of products

## HP StorageWorks Modular Smart Arrays

## HP StorageWorks Enterprise Virtual Array family *(For more advanced, enterprise-level needs)*

Entry-level consolidation	Mid-range consolidation	High-end consolidation
<b>MSA2000i</b>	<b>MSA2000fc</b>	<b>EVA4400, EVA6100 and EVA8100</b>
Flexible	Flexible, scalable	High-performance and high-availability virtualised array solution
IP SAN solution	Fibre Channel SAN solution	Fibre Channel SAN solution
SATA and/or SAS	SATA and/or SAS	Fibre Channel and/or SATA
Scale up to 48 TB (SATA) or 14.4 TB (SAS)	Scale up to 48 TB (SATA) or 14.4 TB (SAS)	Scale up to 240 TB (EVA8100) using 1 TB SATA drives
Consolidate multiple servers in an IP SAN	Enhanced storage consolidation in a Fibre Channel SAN with multi-server clustering	Easy manageability and virtualisation allows consolidation of multiple storage devices
Redundant controllers, cooling and power supplies	Redundant controllers, cooling and power supplies	Redundant architecture and broad choice of software, including local and remote replication
Windows Linux VMware	Windows Linux VMware	Windows Linux HP-UX Tru64 UNIX, OpenVMS Solaris, AIX, Novell, NetWare VMware Macintosh
Data replication and server fail-over over LAN or WAN in Windows and Linux environments <sup>1</sup> Snapshots Clones	Data replication and server fail-over over LAN or WAN in Windows and Linux environments <sup>1</sup> Snapshots Clones	Virtual Snapshots (Vsnapshots) Virtually instantaneous snap clones for back-up and restore; remote replication; HP Pay per use for storage capacity and software

<sup>1</sup> Using HP StorageWorks Storage Mirroring

# Part 4:

## Complete your knowledge

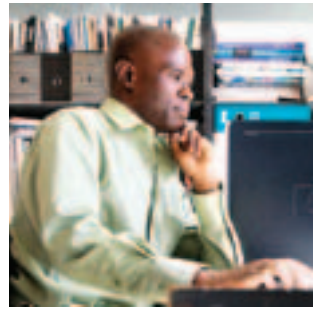

### How HP Services can complement your solutions

Regardless of the size of your business – small, medium, or large – one aspect is the same: Over time, business needs change. HP Services recognises the dynamic, fluid nature of business and provides a total care approach geared towards every aspect of your IT environment and at every point of the IT life-cycle – design, integration, data migration and support.

#### **HP Care Pack Services**

HP Care Pack Services create a simpler, more affordable services solution scaled to the needs of small and mid-sized businesses. The services can supplement existing technical resources so that smaller businesses can spend less time focusing on technology – and more time focusing on business.

HP provides support for your SAN solution with a full range of HP Care Pack services that can:

- Save you time by speeding up the installation process of your solution
- Extend your standard warranty for longer investment protection
- Enhance your service level
- Provide phone assistance and licence updates on your software components
- Reduce costly downtime and improve employee productivity

#### **Mission-Critical Services**

The following services combine reactive technical assistance with proactive account services for selected distributions of Windows and Linux, storage and/or SAN systems:

- HP Proactive Essentials (PE) Service is an entry-level, mission-critical package that increases system performance, expedites problem resolution and decreases downtime caused by software defects.
- HP Proactive 24 Service and HP Critical Service are high-end, mission-critical packages for demanding support requirements where data loss or downtime would put your business at risk.



### **Advanced services**

HP Services also provides a range of advanced services that can assist you in the design, integration and maintenance of your storage environment and SAN infrastructure.

- SAN Solution Service encompasses all the activities required for fast, efficient and successful implementation of your SAN infrastructure devices – with minimal disruption to your operations. We help you get maximum peace of mind and a rapid return on your SAN investment – together with assistance in critical areas such as SAN management, data protection and recovery.

### **HP Assessment Service for SANs**

If you are new to SANs or are experiencing extensive growth and need to better manage your SAN environment, you should consider the HP Assessment Service for SANs. Without requiring SAN downtime, this service provides a snapshot of your SAN environment as well as recommendations for improving the availability levels and ongoing management of your storage devices and SAN environment.

For more information about HP Services and support, contact your HP sales representative or HP Authorised Channel Partner, or visit:

[www.hp.com/go/storageservices](http://www.hp.com/go/storageservices)

# Your questions answered

## **What happens if I need to add more storage capacity after I deploy my SAN?**

HP StorageWorks Modular Smart Arrays, All-in-One Storage Systems and EVA4400 are modular, so that you can add capacity – internally or externally – with additional disk enclosures as your needs grow:

- Scale up to 4 TB on the MSA500 G2 without external expansion
- Scale up to 48 TB SATA or 14.4 TB SAS with three MSA2000 storage array enclosures
- Scale up to 45 TB SATA or 18 TB SAS on the AiO1200 with a Smart Array P800 controller and four MSA60 enclosures
- Scale up to 72 TB SATA or 28.8 TB SAS on the AiO600 with eight MSA60 systems
- Scale up to 96 TB of Fibre Channel storage on the EVA4400

If you need even more capacity, simply add more MSA or EVA4400 systems to your SAN.

## **How many servers can I add?**

The MSA2000sa supports the direct connection of up to 4 servers. The MSA2000fc disk array is tested to support up to 64 servers. For connections to more than 20 hosts, we recommend that you deploy an additional disk array and split the workload.

The MSA2000i also supports up to 16 servers, but, due to the limited network performance of the IP SAN, the I/O requirements of the servers will determine if you can achieve satisfactory performance.

The HP StorageWorks All-in-One Storage System can provide connectivity that is similar to the MSA2000i, depending on the model chosen and the I/O requirements of your application. Smaller All-in-One models are designed for fewer server connections with typical deployments of two to four hosts.

The EVA4400 storage array can support up to 256 hosts connected in a multi-path configuration and up to 512 hosts connected in a single-path configuration.

## **How do I adjust my back-up strategy to match my storage consolidation solution?**

To learn more about the HP StorageWorks data protection solutions that can keep your data safe and secure, please refer to the HP Simply Business Protection solution guide.

### **How can I expand the Fibre Channel connections in my SAN?**

If the number of servers exceeds the number of Fibre Channel ports, you can simply add another Fibre Channel switch to your infrastructure – a process called cascading (see specifications on how your switch supports cascading). For extensive configurations, we recommend that you work with your preferred HP storage partner.

[www.hp.com/go/san](http://www.hp.com/go/san)

### **How does HP StorageWorks Storage Mirroring software increase the availability of data?**

HP StorageWorks Storage Mirroring is a cost-effective software solution that replicates data at a file and byte level and monitors data continuously to replicate only the file changes that occur.

It gives you:

- An effective disaster-recovery strategy – replicating data from multiple servers off site
- Centralised back-up – eliminating dependence on a back-up window and the need to work with live production data
- Automatic or manual fail-over capabilities – helping to ensure business continuity and data availability in the event of a disaster
- A means of integrating dissimilar servers and storage arrays

# Jargon buster

Simple definitions of key technology terms used in this guide.

## **Cascading**

The ability to connect switches to one another to create a larger SAN fabric.

## **Direct-attached storage (DAS)**

A deployment of dedicated storage devices for each server, usually using SCSI connections.

## **Fibre Channel**

A protocol designed for high-speed storage networks requiring high availability. SANs use fibre-optic cabling to connect different devices.

## **Host bus adaptor (HBA)**

A PCI adaptor that connects a server to the SAN fabric. Each HBA installed is referred to as a host interface.

## **IP and iSCSI protocol**

iSCSI is a storage networking protocol that uses standard Ethernet-based Internet Protocol (IP) networks. iSCSI is especially attractive for small environments that do not have the performance and scalability requirements of Fibre Channel.

## **Logical unit number (LUN)**

A LUN is a logical unit number, which is really a logical volume. The operating systems and the software on them operate against a logical volume and view it as a linear address space of fixed-size blocks. A physical disk can be set up to be one large LUN or carved up into multiple LUNs.

## **Network-attached storage (NAS)**

Dedicated turnkey file-serving solutions that are fast to install and easy to manage. They are typically optimised for file-serving performance because they are tuned for a single function. The HP ProLiant Storage Server and All-in-One Storage Systems are example products with NAS capabilities.

## **Network interface card (NIC)**

Network cards used in servers, usually to connect them to an Ethernet network. They perform the same function as an HBA for Fibre Channel connections.

## **Redundant array of independent disks (RAID)**

A method of writing data simultaneously over multiple disk drives used in disk arrays for greater data protection and/or increased performance.

### **Replication**

Mirroring data between two arrays – usually located in separate data centres – to achieve the highest availability in case of failure of one data centre. This can be achieved via host/IP-based replication or – for enterprise arrays such as EVA or XP – via SAN-based replication directly between two arrays.

### **SAN fabric**

The hardware that connects workstations and servers to storage devices in a SAN. The SAN infrastructure allows any-server-to-any-storage-device connectivity through Fibre Channel switching.

### **Serial Attached SCSI (SAS) interface**

A next-generation SCSI interface that uses serial technology. The term SAS can be used to describe individual hard drive technologies as well as connectivity between a server and an external device.

### **Serial Advanced Technology Attachment (SATA)**

Interface technology for disk drives, providing the lowest cost per megabyte. It is ideal for storing file data, secondary application data, or low-usage reference information (an increasing regulatory requirement). SATA provides basic reliability and performance compared with SCSI (and Fibre Channel) HDDs.

### **Small Computer System Interface (SCSI)**

A protocol used to communicate with SCSI devices. It is also used by Fibre Channel technology to communicate with disk drives.

### **Storage area network (SAN)**

High-speed, special-purpose network connecting different data storage devices to servers. SANs may extend to multiple or remote locations for back-up and archival storage.

### **TCP/IP Offload Engine (TOE) card**

Network cards that offload network protocol tasks from the standard server CPUs.

### **Unified storage**

A set of technologies that allows storage devices to perform two roles – both NAS file serving and SAN with the same storage appliance.

### **Virtualisation**

Technologies that help remove physical storage boundaries by treating all available storage, regardless of its location, as one ‘virtual’ pool.

# Simply StorageWorks

## Storage is easy when you choose HP.

For information on Simply StorageWorks solutions, visit:

[www.hp.com/eur/simply](http://www.hp.com/eur/simply) (Europe, the Middle East and Africa)

[www.hp.com/apac/simply](http://www.hp.com/apac/simply) (Asia, Australia and New Zealand)

© Copyright 2007, 2008 Hewlett-Packard Development Company, L.P. The information contained herein is subject to change without notice. The only warranties for HP products and services are set forth in the express warranty statements accompanying such products and services. Nothing herein should be construed as constituting an additional warranty. HP shall not be liable for technical or editorial errors or omissions contained herein.

Microsoft and Windows are U.S. registered trademarks of Microsoft Corporation. Oracle is a registered US trademark of Oracle Corporation, Redwood City, California. UNIX is a registered trademark of The Open Group.

4AA0-7822EEW Rev. 3, June 2008



Technology for better business outcomes